

Inlay XCTF-8030A-C03+FSI

Ultra High Frequency 860-960MHz
Robust Design & Exceptional Performance

Overview

The Invengo UHF Inlay XCTF-8030A-C03+FSI consists of 860-960MHz transponders that are compliant with EPCglobal Class 1 Gen 2 standard (ISO18000-6C).

These products offer four memory banks, including 240-bit EPC number, 64-bit Tag ID and 512-bit programmable user memory, which can each be independently locked with a password to prevent overwriting. In addition, the locking structure is protected by a 32-bit password, offering a stronger level of security.

Combining well with Invengo UHF readers, the XCTF-8030A-C03+FSI delivers exceptional EPC Gen 2 range and reliability at competitive price.

The delivery format is wet inlay.

Features

- EPCglobal Class1 Gen2 (ISO18000-6C) compliant
- Operating frequency 860-960 MHz
- Read / Write
- Fast read rates for dense reader environments
- Anti-collision
- 64-bit TID
- Kill command set
- Scalable Production & Conversion
- Exceptional performance at Low Cost

Applications

Retail

Distribution Logistics

Work in Process (WIP)

Specifications

Inlay XCTF-8030A-C03+FSI

Physical Characteristics

Dimensions

94 × 20 × 0.2mm
(3.7 × 0.79 × 0.01in)

Base material

PET; aluminum

User Environment

Operating temperature

-20°C to +75°C
(-4°F to +167°F)

Storage temperature

-20°C to +80°C
(-4°F to +176°F)

Inlays per roll

5,000

Package

Corrugated Carton

Rolls per carton

up to 6

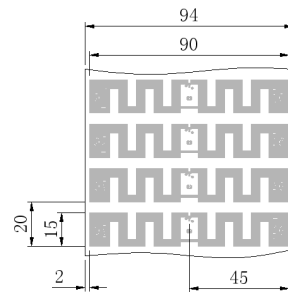

Inlay Layout
All measurements in mm

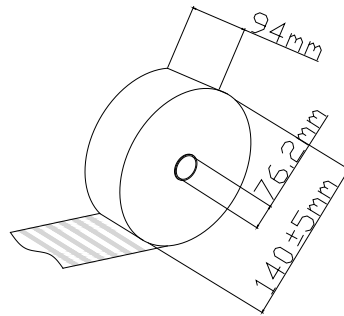

XCTF-8030A 5000pcs/roll)

Inlay Roll
All measurements in mm

Performance Specifications

Operating frequency

860-960MHz

Supported standard

EPCglobal Class 1 Gen 2;
ISO 18000-6C

Read distance

Up to 7m / 23.0ft
(reader dependent)

Chip type

UCODE G2XM

Memory

240-bit EPC; 64-bit TID;
512-bit programmable user memory;

Data retention

> 10 years

About Invengo

Incorporated in 1999, Invengo Information Technology Co., Ltd. is a leading vendor of RFID technology and products in China. Invengo (stock symbol: 002161) is a public company listed in SZ Stock Exchange, China.

Invengo lineup consists of 6 series and more than 60 models of RFID products: fixed and handheld reader, reader module, antenna and inlay/label/tag. Invengo has been successfully providing RFID solutions and service to various sectors: railway/transportation, warehouse management, intelligent traffic/ETC, logistics and supply chain, library, assets tracking and management, etc. Invengo Performance Test Center is one of the eleven EPCglobal Accredited Test Centers around the world to perform tagged unit performance testing in a variety of real-world environments common with the supply chain.

Invengo's up-to-date production facility provides quality and economical RFID transponders in the forms of inlay, label, ticket and card, with a capacity of 150 million pieces annually.

Invengo is an ISO 9001: 2000, ISO14001 certified company and member of EPCglobal(China) and AIM(China).

Contact us

Corporate Headquarters

3/F, Bldg.T2-B, High-tech Park South,
Shenzhen, Guangdong 518057 China
Tel: (86) 755 26525585
Fax: (86) 755 26525277
intl@invengo.cn

Invengo Technology Corp. (USA)

12801 Worldgate Drive, Suite 500
Herndon, VA 20170, USA
Tel: (1) 703 793 0085
Fax: (1) 703 871 3901
sales@invengo.com